

> WC pack DELUXE SAMOA



COMPLETE PACK IN 1 BOX



DESCRIPTION

- > BCM 350, wall fixing. Dual flush outlet valve, factory preset 4/2.6 litres flush, NF approved. Water saving and quiet fill delayed action inlet valve, NF approved. Conforms to EN 14055 Class 2 flushing standards, BREEAM requirements and UK Building Regulations. See page 19 for more details
- > Front flush plate operation. Supplied with bright chrome Smarty, dual flush plate, NF approved (see page 46 for more details), WC connector and drainage set
- > White wall hung ceramic rimless hygienic WC Vitra S50. Conforms to EN 997 Class 2 flushing standards, BREEAM requirements and UK Building Regulations
- > White thermoset Principauté Premium toilet seat, anti-bacterial, scratch resistant, soft close, with adjustable stainless steel hinges. See page 82 for more details

WATER SAVING:
DUAL FLUSH 4/2,6 LITRES

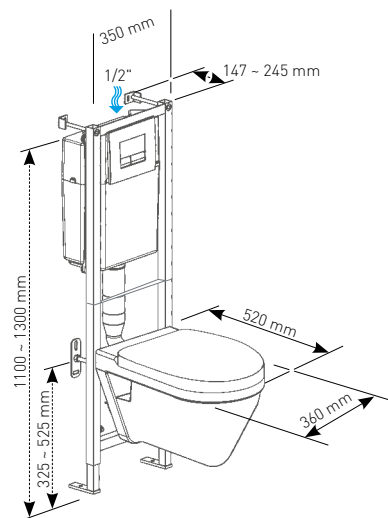

TEXT FOR TENDERS: WC PACK DELUXE SAMOA Ref.: 31 2338 10

Complete pack comprising BCM 350 wall frame, 6 litre insulated cistern with NF approved components. Factory preset at 4/2.6 litres with integral dual flush outlet valve and a water saving and quiet fill delayed action inlet valve. Water inlet connection on the inside of the cistern fitted with an integral isolating valve. Front flush plate operation.

Supplied with fixing accessories for floor or wall fixing, dual flush plate, accessories for protection during the construction phase, ceramic rimless wall hung WC, thermoset anti-bacterial, soft close, white toilet seat, 90° outlet pipe and WC connectors.

	Ref.	Barcode	Packing	Packing			Pallet quantity
				Nb	M ³	Kg	
WC pack DELUXE SAMOA	31 2338 10	3 24723 009409 7	Carton	1	-	42,00	15



For more information:
Web: siamp.co.uk