

> Hydraulic with delayed action

95 OD



DESCRIPTION

- > Ultra quiet : 16 times more quiet than a traditional inlet valve
- > The delayed action opening case delays the filing of the cistern while the flush valve is open
- > Can be installed into ceramic or plastic cisterns, recessed or low level, for replacement or as original equipment
- > Compact
- > Hydraulic closure (no water hammer shock)
- > Adjustable water level
- > Anti-backflow function
- > Nickel coated 3/8" brass end-fitting
- > Flow rate: 0.12 l/s at 3 bars
- > Pressure function range: from 0.5 to 12 bars

DELAYED ACTION MECHANISM



The cistern empties quicker than the water in the delaying case, keeping the inlet valve closed.

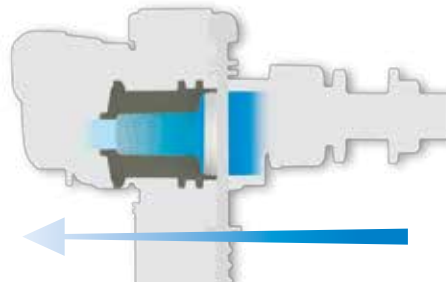

A case full of tiny marbles reduces the water pressure that comes through the inlet. This reduced flow makes the inlet ultra quiet.



Once the flush is complete and the flush valve closes, the delaying case keeps draining water which then allows, the inlet valve open and refill the cistern.

TEXT FOR TENDERS:

95 OD

Ref.: 30 7781 10

Side entry inlet valve with 3/8" brass connection, NF certified and 10-year-warranty. Features: ultra quiet and water saving, hydraulic closure, adjustable water level and anti-back flow. Length 256mm, width 112mm, depth 69mm.

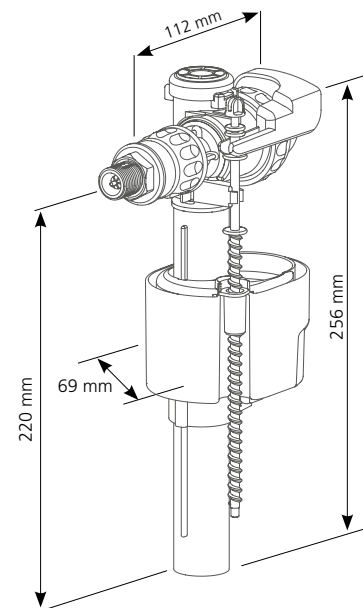

	Ref.	Barcode	Packing	Packing			Pallet quantity
				Nb	M ³	Kg	
95 OD	30 7781 10	3 24723 007126 5	Box	20	0.08	7.08	300

*Based upon a 4-people-family consumption when replacing a standard inlet valve



For more information:
Web: siamp.co.uk